



**DICKOW  
PUMPEN**



**Submersible Long Shaft Pumps  
for the Chemical Industry  
Type NCT / NMT**

## General

The DICKOW submersible pump, type NCT / NMT, for the chemical industry is a vertical pump with separate discharge pipe.

The maximum capacity and differential head goes up to 900 m<sup>3</sup>/h and 150 m (at 50 Hz).

## Application

The pump type NCT / NMT has been developed for chemical, petrochemical and related industries. With a wide selection of materials, the DICKOW submersible pumps are suitable for handling almost all liquids which are used in above mentioned industries.

For example: acids, lyes, hydrocarbons, condensation products, solvents etc.

## Hazardous area

Together with the required Ex-drive motors, the NCT / NMT-pumps can be applied in hazardous area Group II, Category 2. The pumps meet the basic safety and health requirements of Explosion-proof Directive 94/9 EC and are suitable for plants with increased safety requirement.

## Design

The chemical submersible pump NCT / NMT is a single-stage, single-flow volute casing pump with separate column pipe and discharge pipe.

The hydraulic part of the pump is mounted inside of the vessel, the driving motor is located outside. All standard motors with normal shaft design can be used. No special shaft design is required.

The motor shaft is connected with the pump shaft via an elastic coupling. By using spacer-type couplings, service on ball bearings or on the available shaft sealing system can be performed without removing the motor. Submersible length according to customer's specification.

## Volute casing

The volute casing is a one piece casting and bolted to the column pipe via the intermediate casing. In case the liquid temperature drops below the melting or crystallization point, volute casings and tubes with heating jackets are available. For example: handling of liquid sulphur or viscous residuals or sump liquids.

## Impeller

The standard design of the DICKOW submersible pump has a closed impeller. The impeller is cast in one piece and hydraulically balanced to reduce thrust loads to a minimum. Residual loads are carried by the double ball bearings located in the motor support lantern. All impellers are dy-

namically balanced, according to DIN ISO 1940T1 balance grade 6.3 which grants a smooth vibration free operation. Finer balancing grades are available on request.

The impellers are placed on the pump shaft in overhung position and secured by key and shaft nut with Heli-Coil insert.

## NCT o-design

For handling liquids with solids or suspensions, the type NCT o with open impeller is also available. The NCT o-pumps are fitted with renewable wear disks to minimize maintenance costs.

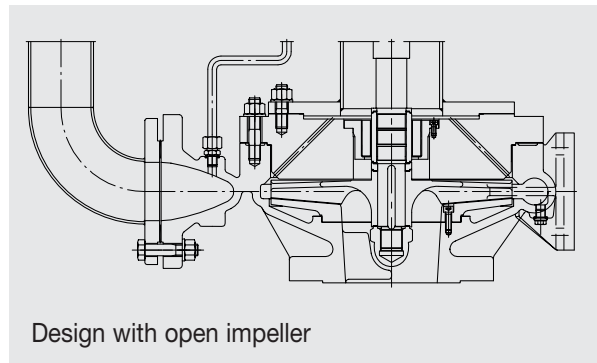

## Wear rings

The volute casings and the intermediate casings of the NCT-pumps are fitted with renewable wear rings as standard. The running clearances between casing wear rings and impeller comply with the recommendation of API 610.

## Shaft

The shaft assembly consists of the drive shaft, one or more intermediate shafts and the pump shaft. These shafts are connected by rigid metallic plug-in couplings, secured by keys and locking fasteners.

## Discharge pipe, column pipe

The discharge and column pipes consist of seamless pipe material with welded connection flanges.

## Dome cover plate (mounting flange)

The cover plate with the drilled holes for pump installation on site is made according to customer's specification, or approved dimensional drawing.

If the pump is supposed to be installed in a pressurized vessel, the thickness of the cover plate will be calculated and sized according to the German Pressure Vessel Code.

## Bearings

The intermediate shafts and the pump shaft are guided by sleeve bearings which are corrosion and abrasion resistant. The maximum space between the shaft guide bearings follows the recommendation of API 610.

The drive shaft is carried in two angular ball bearings. These bearings are grease lubricated and protected against shaft sealing leakage by two grease filled radial seal rings.

Several sleeve bearing options are available. E.g. for handling liquids with solids we can offer pure and wear resistant Silicon Carbide bearing sets.

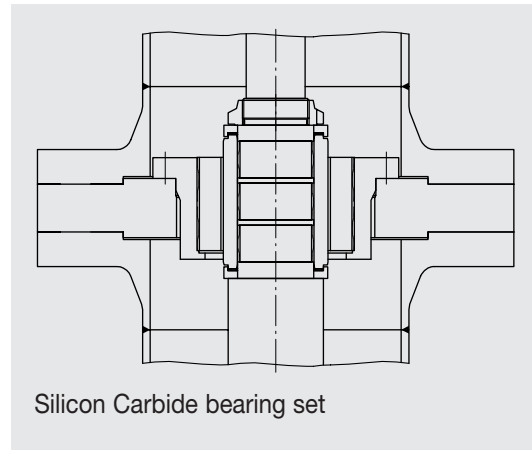

## Motor support lantern

The welded motor support lantern is made of fabricated steel. Ball bearings and shaft sealing are integrated in the support lantern. The lantern is machined in a way that alignment to the cover plate and alignment of drive shaft and motor shaft is guaranteed.

## Standard materials

(Special materials available as an option)

Pump type	NCT s / NMT s	NCT hu / NMT hu	NCT h / NMT h
Volute casing	EN-GJS-400-18-LT	GP 240 GH	1.4408
Impeller	EN-GJL-250	EN-GJL-250	1.4408
Cover plate	St	St	1.4571/St
Shafts	1.4057	1.4057	1.4571
Sleeve bearing casing	EN-GJL-250	EN-GJL-250	1.4408
Motor support lantern	St	St	St/1.4571
Bearing housing	EN-GJL-250	EN-GJL-250	EN-GJL-250
Tubes	St	St	1.4571
Column pipe	St	St	1.4571
Discharge pipe	St	St	1.4571

Ductile iron	EN-GJS-400-18-LT → A 395	1.4408 (G-X5 CrNiMo 18.10) → A 296 CF8M
Cast iron	EN-GJL-250 → A 48 No 30	1.4571 (X10 CrNiMoTi 18.10) → AISI 316L
Cast steel	GP 240 GH → A 216-WCB	1.4057 (X22 CrNi 17) → A 431
Carbon steel	St → A 53 Gr.A.	

## Sectional drawings

### Standard design NCT

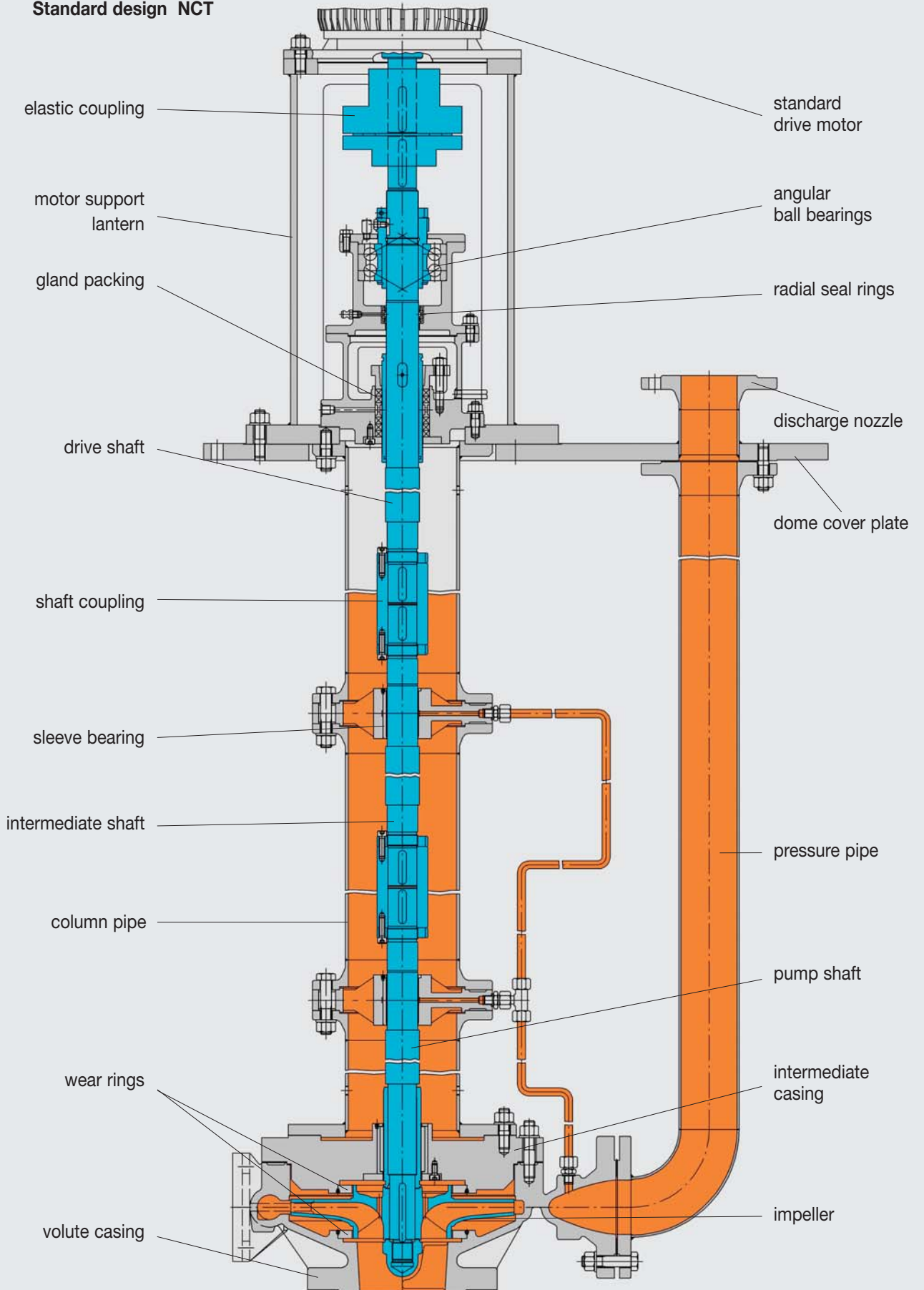

**Optional designs**

**Magnetic coupled design, type NMT**

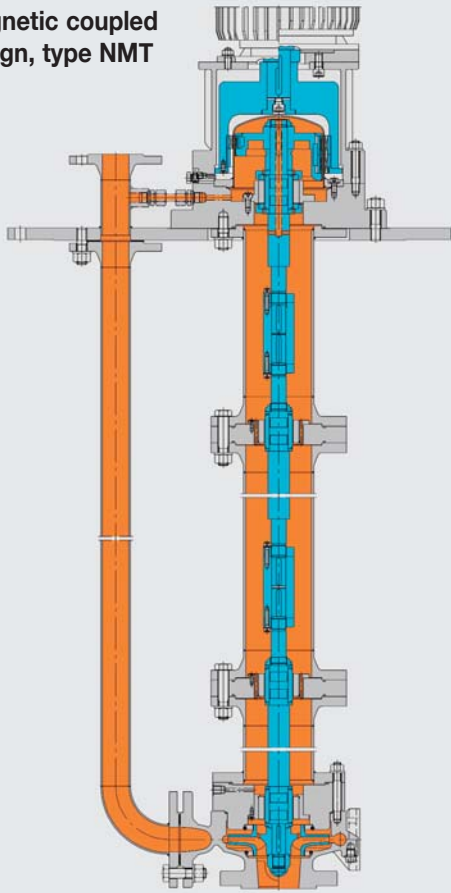

**Type approved ATEX design, NCT Cat.1**

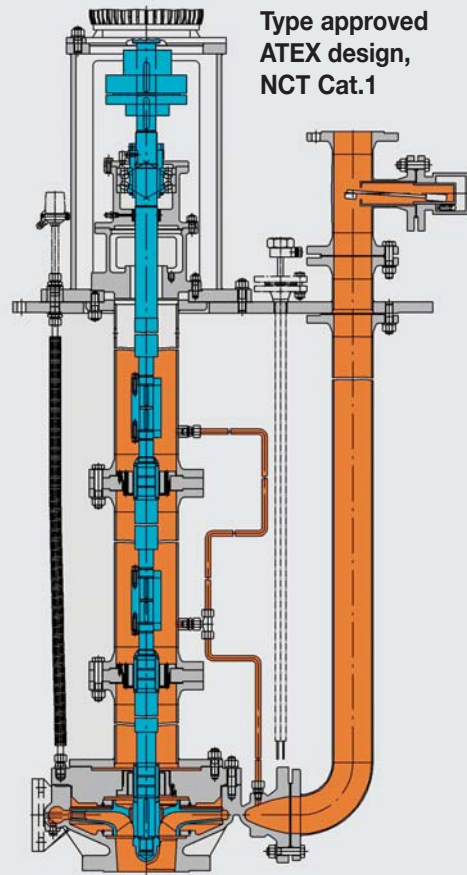

**Cantilever design, type NCTk**

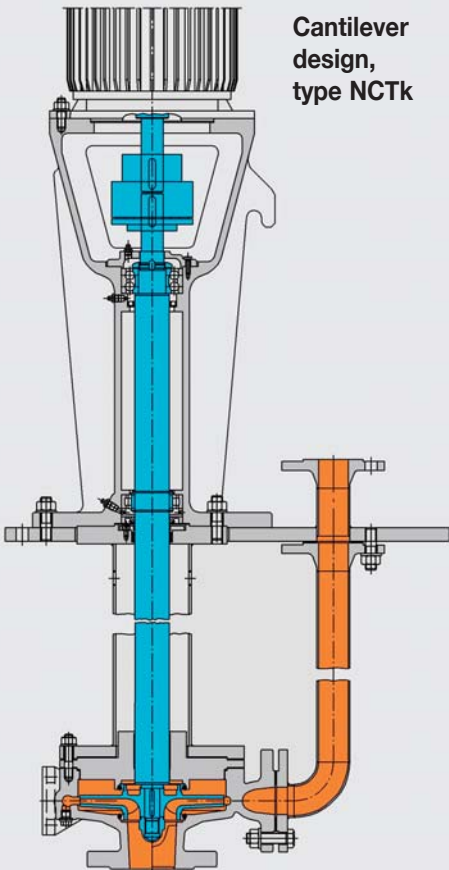

**Jacketed design, type NCT b**

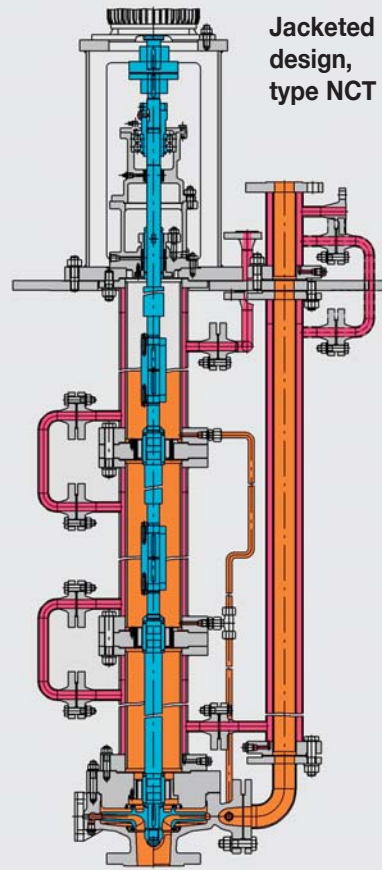

**Optional designs**

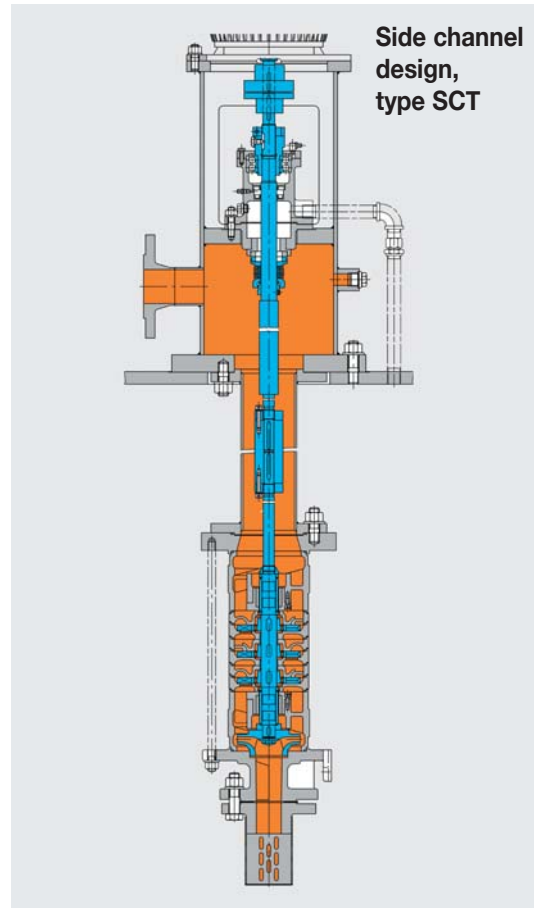
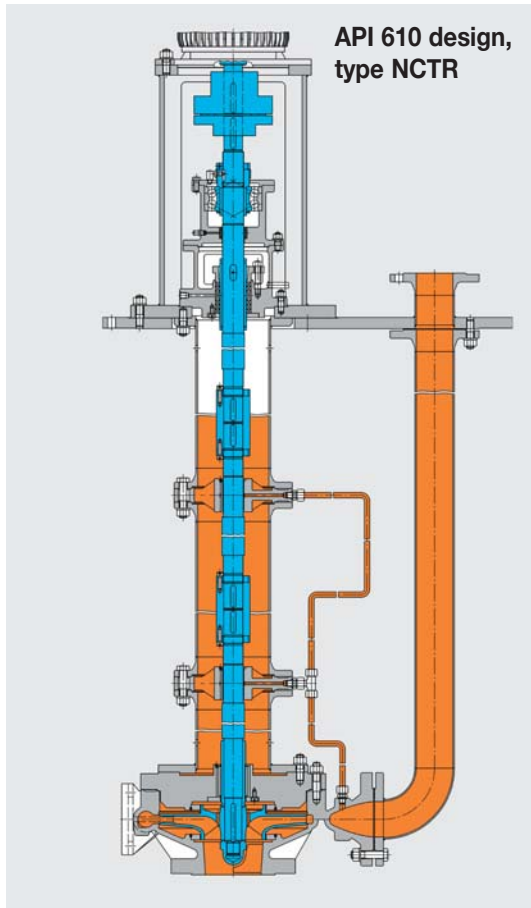

Design features:

- mechanical seal acc. to API 682
- impeller and casing wear rings

Special design for low flow and high head applications. Pump body and performance table is identical to type SC (see corresponding leaflet).

**Shaft sealing**

The drive shaft is sealed against the atmosphere by a shaft sealing arrangement, located in the motor support lantern.

**Examples of available seals**

**Design "Cartd"**

Double mechanical seal, Cartridge design.

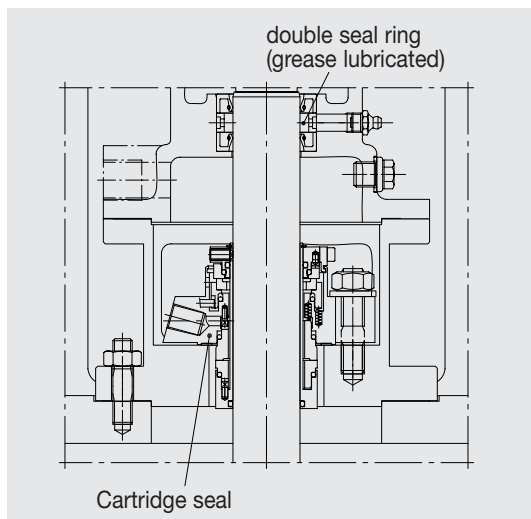

**Design "Plan 11"**

Single mechanical seal acc. to API 682, Cartridge design.

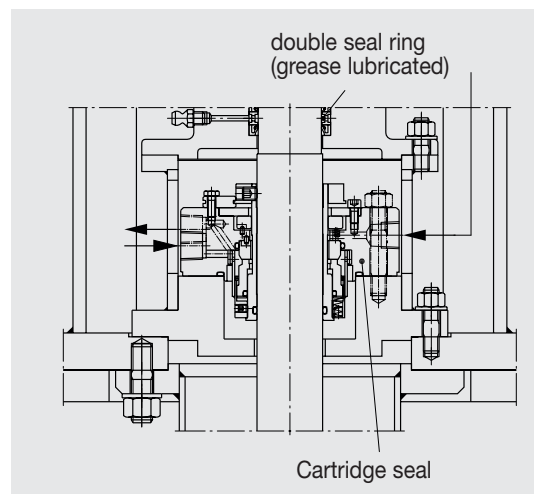

## Performance range

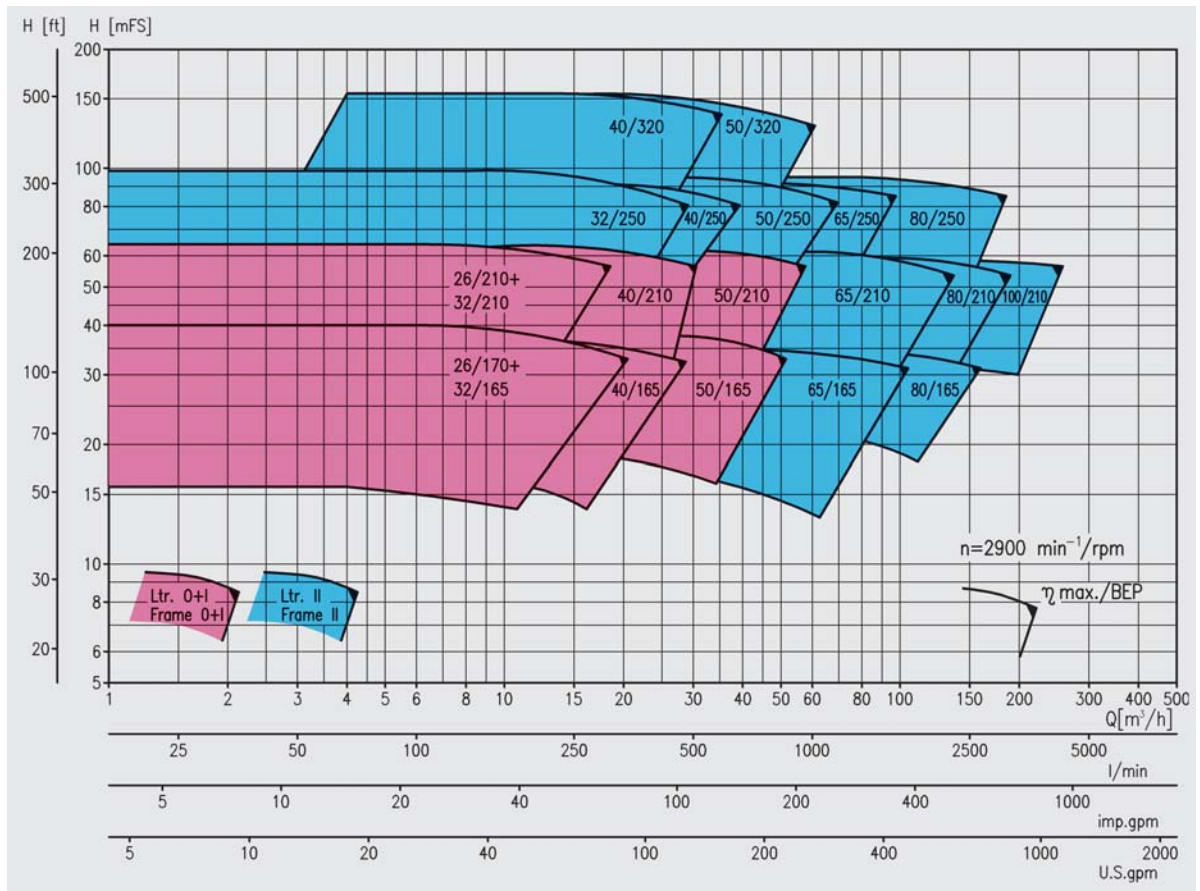
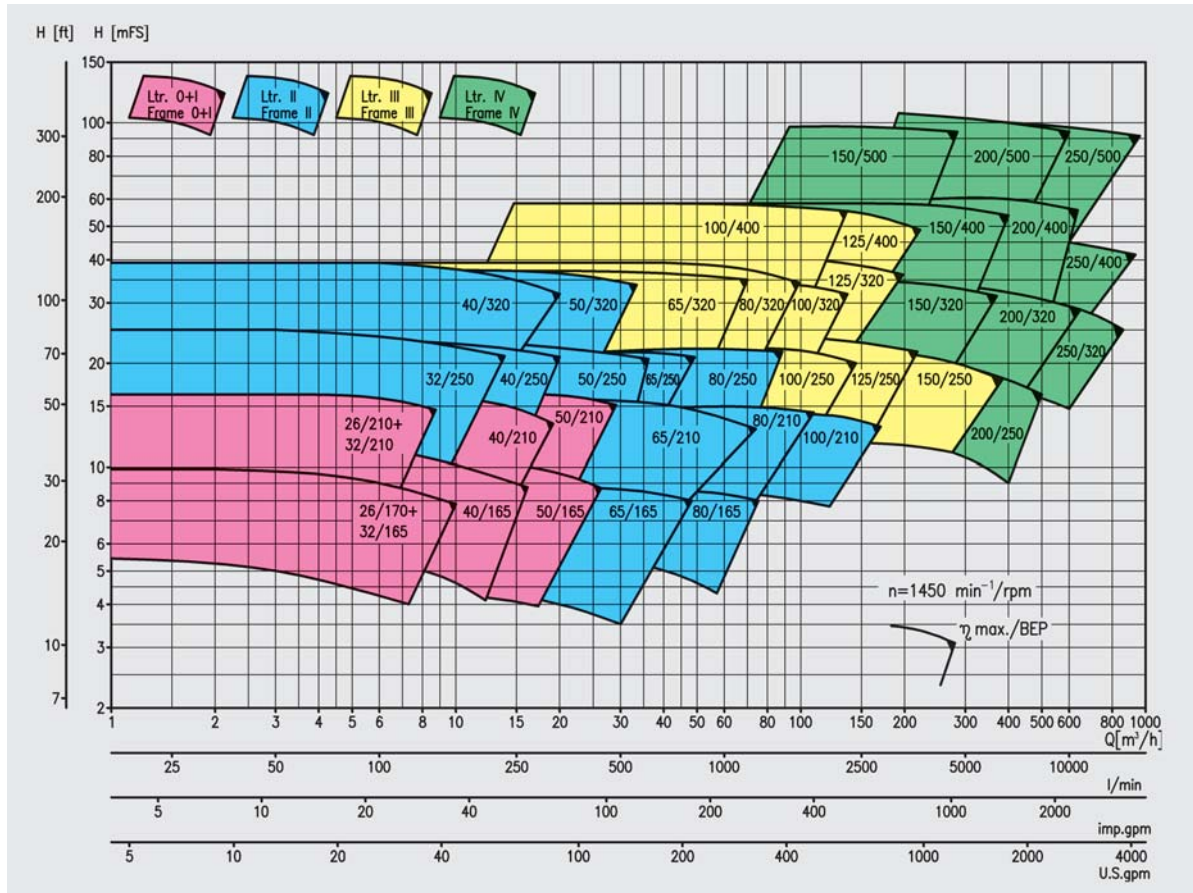

Performance curves for the different pump sizes are available on request and are supplied with our technical offers in general.



DICKOW PUMPEN KG  
P.O.Box 1254  
84465 Waldkraiburg · Germany  
Phone ++ 49 86 38 6 02 0  
Fax ++ 49 86 38 6 02 200 + 6 02 201  
info@dickow.de / export@dickow.de  
www.dickow.de

